

# RANELLE SOTTOVITI

## CONICAL WASHERS

ART. 505

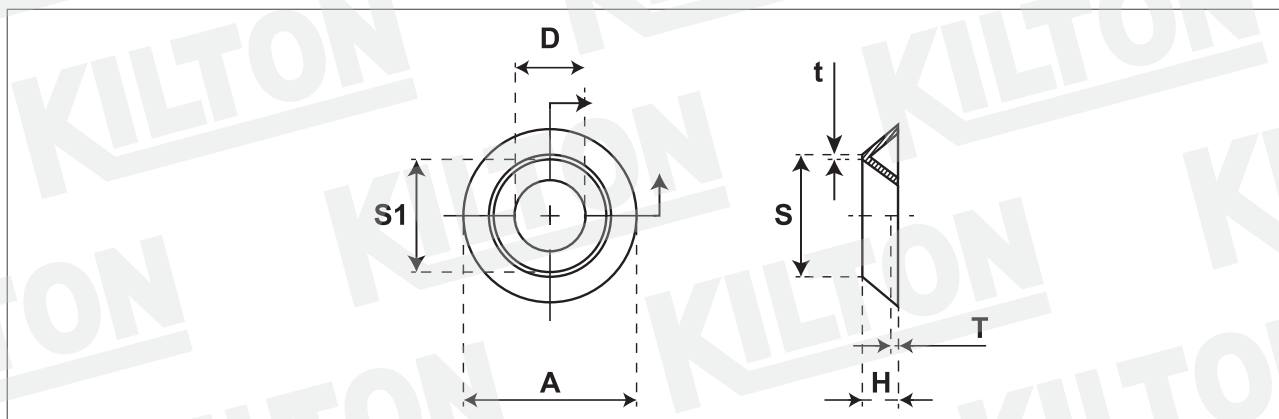

Quantità - Quantity

Materiale - Material

C1006

Lunghezza Ribattino - Shank length

Lunghezza Vite - Screw length

Durezza superficie - Surface hardness

Hv Min. 100

Durezza a cuore - Core hardness

Testa Rif. - Head according to Uni/Din

Filetto Rif. - Thread according to Uni/Din

Trattamento superficie - Surface treatment

Zincate Cr3

SIZE	A		S		S1		D		H		T		t	Case Depht mm.	Torsion min. Kg./cm.
	min	max	min	max	min	max	min	max	min	max	min	max			
M6	18,50	21,50	14,50	17,50	13,50	15,50	7,00	9,00	3,50	5,50	1,50	3,50	0,70		
M8	23,50	26,50	17,00	20,00	16,00	19,00	8,00	10,00	4,50	6,50	1,80	3,80	1,20		
M10	30,50	33,50	22,00	25,00	21,00	24,00	11,00	13,00	5,50	7,50	2,50	4,50	0,70		

Lunghezza nominale/Nominal length:

Disegno/Drawing: KLT-B2-0208/1 ART.505

Cod. cliente/Client code:

Confezione/Packing: Box

Note:

**KILTON**  
PRODUZIONE VITERIE